

Branch Expansion PLC



Velocio's Branch Expansion PLC

The Branch Expansion PLC is a member of the Velocio's groundbreaking series of programmable logic controllers. These PLCs introduce revolutionary new concepts, capabilities, performance and ease of use features to the automation market. They constitute a generational leap over the staid products that have comprised the PLC world for years.

A key feature of the Velocio PLC line is distributed operation. By placing IO and optionally, program intelligence, right at every point of application, historical problems with accuracy, reliability, safety, installation cost, maintenance and others, are radically reduced or eliminated.

Branch Expansion PLCs expand the tree for a distributed system. Each Expansion unit contains up to 30 points of IO and can contain its own program. vLink communications ports on the Branch Expansion communicate autonomously, upstream to the Branch or Expansion unit above it in the tree, and downstream to the next level of Branch Expansion PLCs.

Three levels of Branch Expansions are permissible in a system.

In an application, each Branch Expansion PLC, that is configured as IO, is expansion IO for the next level PLC above it that has a program. If the application places a program in a Branch Expansion, Branch Expansion units that are below it in the tree and configured as IO serve as its expansion IO.

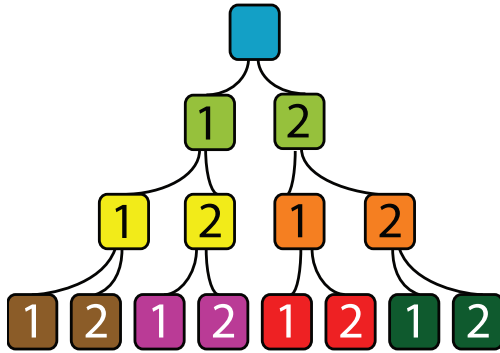

Branch Expansion PLCs are programmable, using Velocio's vBuilder software. They connect to a PC through vLink communications and any Branch and Branch Expansion PLCs above them in the tree. Through a single USB communication link to a PC an entire system of Velocio PLCs can be programmed, debugged and deployed.

Branch Expansion PLCs feature integrated local IO. Up to 12 digital inputs, 12 digital outputs and 6 analog inputs are available. In addition to basic input/output capabilities, the Branch Expansion can be configured for high speed digital pulse counting for either simple pulse or quadrature inputs. It can also be configured for high speed stepper motion pulse and direction control.

This PLC, which fits in a shirt pocket, is a building block of the most advanced, flexible, easiest to develop and deploy automation technology available anywhere.

Available Versions of the Branch Expansion PLC

Exp 11 : 6 digital in, 6 digital out, 2 vLink ports
Exp 22 : 12 digital in, 12 digital out, 2 vLink ports
Exp 221v5 : 12 DI, 12 DO, 6 Analog in (0-5V), 2 vLink
Exp 221v10 : 12 DI, 12 DO, 6 Analog in (0-10V), 2 vLink
Exp 221c : 12 DI, 12 DO, 6 Analog in (0-20mA), 2 vLink

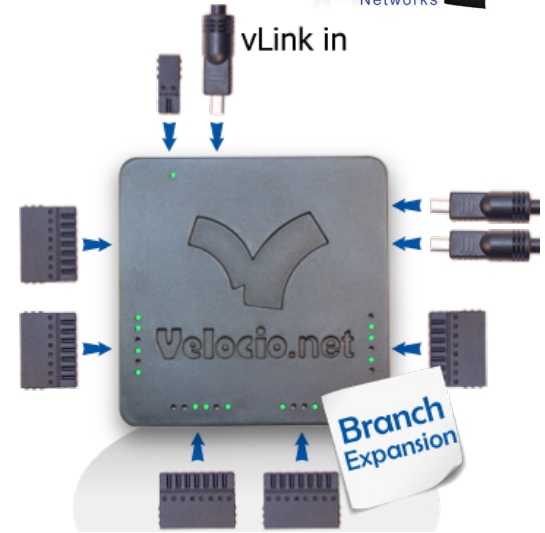

Applications

- Machine control
- Process control
- Entire manufacturing line control
- Building automation
- Distributed system control
- Motion system control
- Robotics
- Machine to Machine applications

Features

- Up to 30 Inputs and Outputs
 - 12 Digital Inputs
 - 12 Digital Outputs
 - 6 Analog Inputs
- Distributed IO Expansion
- Distributed Processing Platform
- vLink Communications with host
- Two vLink Expansion Communications ports
- vLink communications up to 100 meters (328 feet)
- Smallest physical footprint of any PLC
- Software features at or beyond those of the most advanced PLCs and Programmable Automation Controllers (PACs)
- Program development via vBuilder
 - Graphical program development
 - Flow Chart Programming
 - Ladder Logic Programming
 - Distributed Processing
 - Integrated deployment and debug of distributed processing systems
 - Interactive, graphical full system debug functionality
 - Software reusability

Benefits

- Automatic communications between system modules
- Greatly enhanced and efficient development process
- Reduced systems cost
- Reduced development time
- Improved reliability
- Automatic machine to machine operations
- Total system deployment and debug

vBuilder Software



Like all Velocio PLCs, Branch Expansion can be custom programmed for your application's requirements, using Velocio Builder (vBuilder). vBuilder is an application that is distributed free of charge, for use in developing programs for Velocio PLCs.

vBuilder is the most powerful, flexible, intuitive, easy to use graphical program development software available in the industry. That includes the packages from the industry titans, that will cost you hundreds to thousands of dollars. We're sure that you'll love it.

In vBuilder, you can develop applications using either Flow Chart, or traditional Ladder Logic programming.

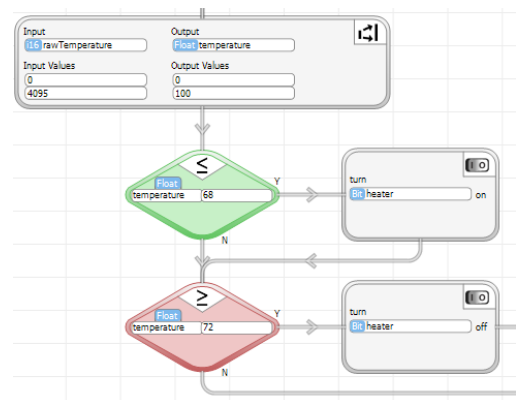

Some vBuilder features include :

- Flow Chart programming
- Ladder Logic programming
- True subroutines
- Object oriented graphical programming
- Distributed program operation
- Single point debug of local or distributed systems

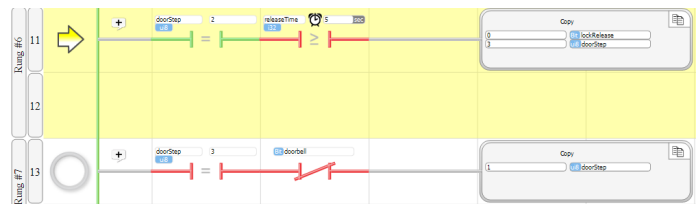

There's so much more. Download vBuilder from Velocio.net to see for yourself. You'll notice very quickly that you can develop any program that you can logically define, in a fraction of the time required using other approaches, with easy to use graphical tools - and its fun!

Distributed IO

In typical control system applications, physical inputs and outputs are located at physically diverse points, commonly in clusters. Traditional PLCs require you to string wire from these distributed locations back to a centralized PLC. This leads to high costs in wiring material and labor. It also potentially results in degraded signal quality, reduced reliability and higher maintenance costs.

Velocio PLCs are designed to allow you to place the IO at the point of application. Each module is linked, via high speed vLink communications. IO modules can be placed anywhere from a few feet apart to 100 meters apart.

The Velocio PLC program treats this distributed IO, just like its local IO. The speed of communication between devices means that sensor status and device activation takes place nearly instantaneously. Wiring time and expense are minimized, while reliability improves and maintenance is reduced.



Distributed Processing

Traditional distributed processing is a very difficult undertaking. Sure, the control devices may have communications ports. But the process of configuring the devices, designing the communications, debugging and deploying is something that can take a very capable system engineer many days to weeks.

Velocio PLCs have been designed for distributed processing from the get go. Developing a distributed processing system, with interlinked, independently operating PLCs is no more involved that writing a subroutine for a local PLC. In fact it is directly analogous to writing a subroutine. Define which PLC device each program gets deployed into, define the data that is passed back and forth, then push the program button. The entire system will be programmed. You need not concern yourself with the details of how data is communicated - its done autonomously over vLink.

Debugging the distributed system is also much simpler than with other such systems. With vBuilder, the entire system's operation can be monitored from one PC. All debug operations, including breakpoints and single stepping can be selectively employed on any device in the system in real time.

Branch Expansion Inputs and Outputs

Each Branch Expansion PLC can directly connect to 6 or 12 digital inputs, 6 or 12 digital outputs and 0 or 6 analog inputs. There are up to 5 IO ports. Each IO port has an 8 pin pluggable terminal block connector. Each of these port connectors connect to 6 points of IO.

The layout of Branch Expansion IO ports (looking from the top of the Branch Expansion), is shown here.

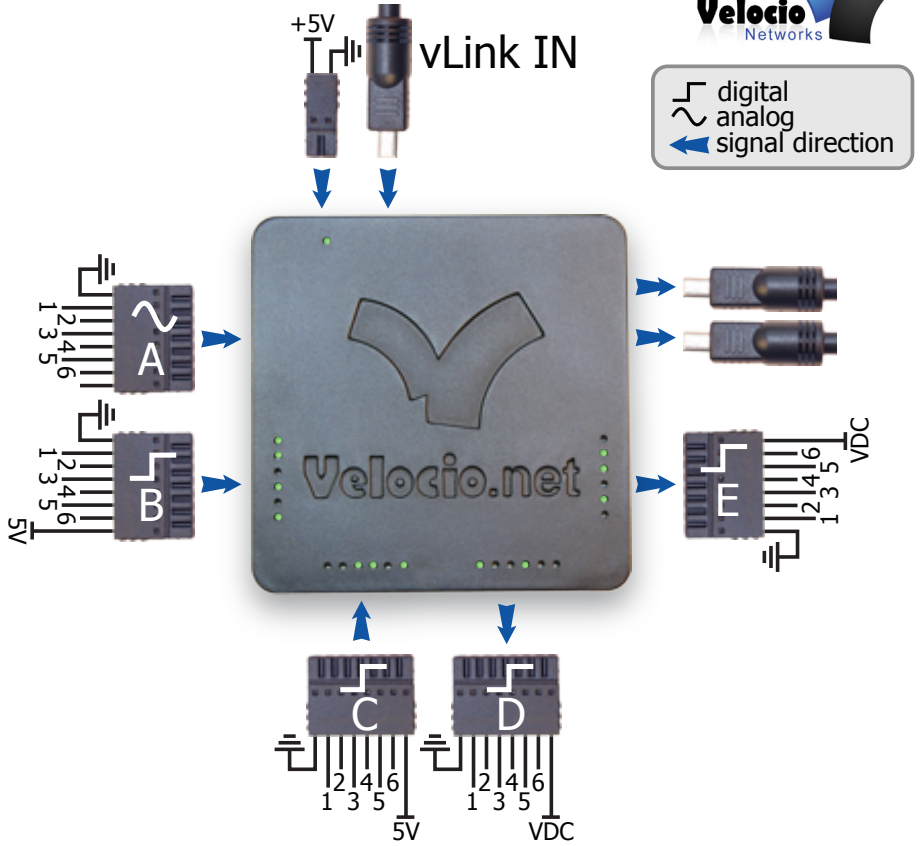

Digital Inputs :

Branch Expansions have either 6 (1 port) or 12 (2 ports) digital inputs. Digital inputs sense binary status, such as on/off, switch open/closed, etc. The Expansion can interface any DC voltage signal between 3 and 30VDC. Typical system designs utilize 5V, 12V or 24VDC power supplies, which are all within the PLC's signal range.

Any connection to DC voltage between 3 and 30 VDC is sensed as a '1'. Any connection to ground (or voltage below 0.8VDC) or an open connection is sensed as '0'. The ground reference of the signal must be connected to the ground terminal pin next to signal 1.

Using vBuilder, one high speed pulse counter can be configured for basic high speed pulse counting (one digital input), or quadrature pulse counting (two digital inputs). The same signal level requirements apply, as listed above.

For digital inputs that are AC signals, the Expansion's digital input ports can be connected to Velocio Optocoupled Input Terminal Block modules. These modules interface 24VAC or 120VAC signals. A cable, supplied with each terminal block module is then connected to the Branch Expansion digital input port. The Optocoupler Input Terminal modules convert the AC signals to the proper DC levels to the PLC.

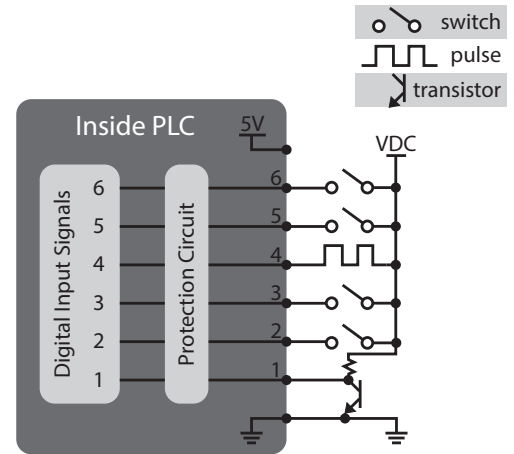

Digital Outputs :

Branch Expansion PLCs have either 6 (1 port) or 12 (2 ports) digital outputs. The digital outputs are sinking transistor outputs. When switched on under program control, they complete the circuit to turn on any connected DC device up to 30VDC and 500mA.

Each output includes diode snubber protection, for inductive load (solenoids, relays, etc.) protection. The supply voltage, up to 30VDC, which is connected to the load devices, must be connected to the VDC terminal pin, next to output 6 of the port, to enable this protection. All loads connected to a digital output port should be connected to the same DC supply. The load power supply ground must be connected to the ground pin (next to signal 1) of the port.

If AC power, or higher power DC needs to be switched, the Branch Expansion's digital output ports can be connected to a Velocio Relay Terminal Block module, through a short standard cable, supplied with the module. With a Relay module, up to 250VAC and 5 Amps can be switched under program control. The cable diagram connection to the PLC digital output port pluggable connector is illustrated in the Relay Terminal Block module documentation.

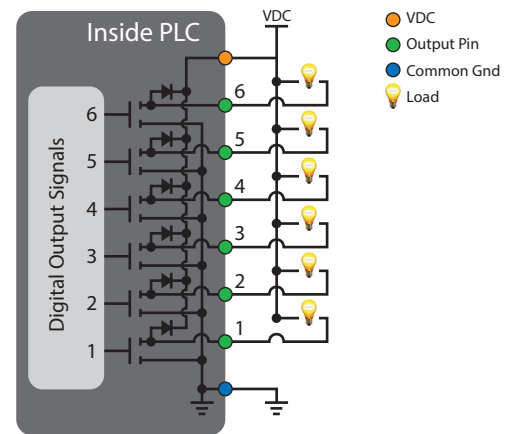

◇ Analog Inputs :

Branch Expansion PLCs are available with 6 analog inputs (1 port). Expansion analog input interfaces are available for either 0-5VDC, 0-10VDC or 0-20mA.



Analog inputs are normally used to connect to transducer outputs. Such transducers measure some physical parameter, such as pressure, temperature, liquid level, position, pH level, or other such continuously variable measurement. The signal output should be connected to a signal input on the Branch Expansion analog port and the transducer return or ground reference line must be connected to the PLC ground pin, next to signal 1.

Branch Expansion PLCs with current input analog ports (Exp 221c) should be used for analog current signals between 0 and 20 mA. The two most common type of current signals are 4-20 mA and 0-20 mA.

Full range analog signals will convert to a value between 0 and 4095 (12 bits). For 4-20mA inputs, the converted value will be between 820 and 4095. The Scale function in vBuilder can be used to automatically convert the signal value to meaningful data.

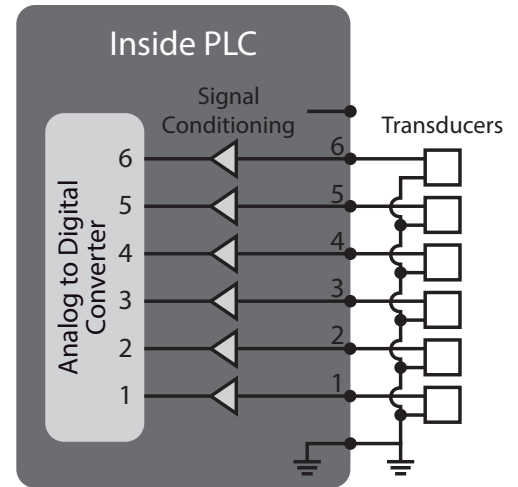

Mounting Options

Each Velocio PLC comes with a double sided adhesive pad for attaching to painted metals, plastics or glass. Using this method of attachment allows you to install the PLC in very tight, unusual environments as well as place them in typical electrical control panels. The adhesive is very strong and will provide a solid permanent attachment, unless extreme pressure is applied to break the seal.



Alternatively, Velocio PLCs are designed to add an optional vMount DIN rail mounting adapter. The vMount adapter snaps onto the bottom side of the PLC. It can then be snapped onto a standard 35mm DIN rail, or can slide onto a pair of properly spaced screws.

DIN rail mounting is illustrated on the right. The necessary hole pattern for screw mounting is shown below.

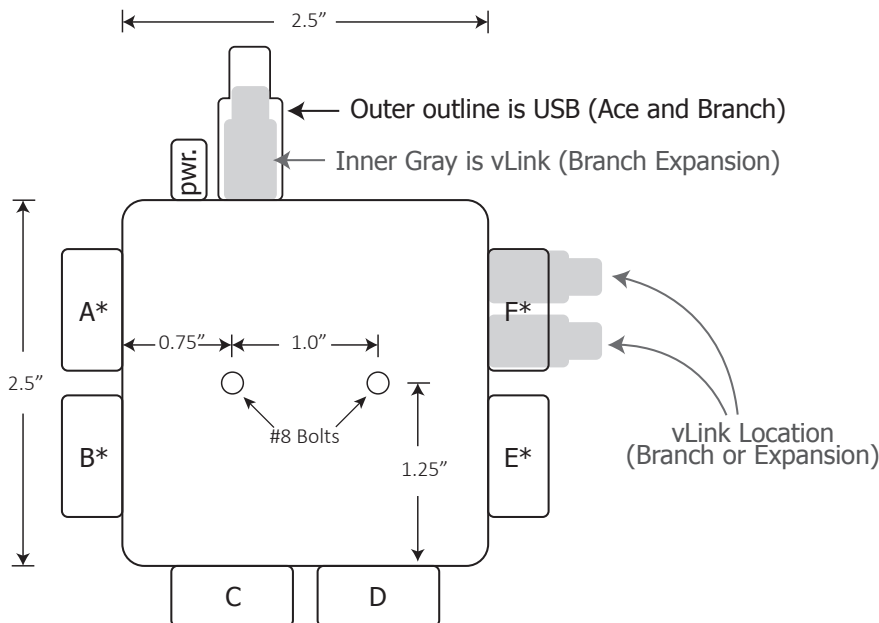
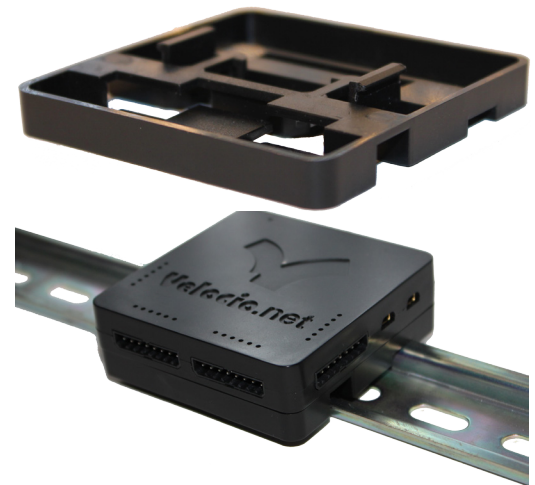

Wire Connections to the PLC Pluggable Terminal Blocks

Branch Expansion units come with pluggable terminal blocks, like the one shown on the on the right. Connect your wires using the larger circular holes on the top row of the orientation shown.

Looking at the connector, in the orientation shown from left to right, the eight wire positions are ground, six signal positions 1 through 6, and either a no connect (analog), VDC (output) or 5VDC from the 5V power input to the PLC (input).

If you have solid wire, you simply need to strip the insulation back about 1/8 inch, insert each wire into the proper round connector hole and push the wire in. It should push in very easily and lock in place. You should not be able to pull the wire back out.

To insert stranded wire, insert the blade of a Velocio connector tool (screwdriver) in the rectangular hole directly below the connection hole which you wish to insert your wire. The screwdriver blade should be horizontal (in line with the long dimension of the rectangular hole). This will open the spring capture connection. Simply push your wire in, then remove the blade. If you pull the wire, it should be captured in place and will not come out.

To remove any wire from the connector, use the Velocio screwdriver connector tool. Push the blade into the rectangular slot below the wire to open the spring clamp and release the wire. Gently pull the wire out, then remove to blade.



Connecting Expansion Units

Connecting the Branch Expansion to a Branch or Branch Expansion unit is a very simple process. If the required connection distance is 6 feet or less, it simply involves plugging a standard vLink cable into one of the two vLink output ports on the higher level PLC and the other end of the cable into the vLink input port of the Expansion unit. vLink cables come in either two or six foot length. Each cable has vLink connector on each end, which look as pictured on the right. The cable connections are identical on both ends. The cable can be connected either way.

vLink port 1 is located closest to digital output port E. vLink port 2 is furthest from digital output port E.

A vLink connection from a Branch or Branch Expansion to a Branch Expansion is shown on the right.



If the required connection distance is greater than 6 feet, the process is not much more complex. You will need a vLink cable for each end of the connection, a pair of vLink Extenders, and CAT5e cable of the length required to span between two devices. This length can be up to 100 meters (328 feet).

A pair of vLink Extenders is pictured on the right. The Extender labeled vLink Out (black label) connects to the vLink cable that is plugged into the higher level Branch or Branch Expansion. The vLink In (white label) connects to the vLink cable plugged into the Branch Expansion's vLink input port.

The vLink Extenders each have an 8 position pluggable terminal block that is the same as used for PLC IO. Instructions for inserting the CAT5e cable in the terminal plugs is included with the vLink Extender pairs.

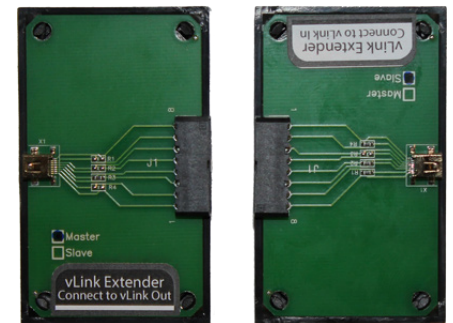

A completed vLink extension is shown in the picture on the right.



Connecting Power

Power to the Branch Expansion PLC must be provided via a two position pluggable connector, included with the Branch Expansion unit. To connect power, insert the 5VDC and ground connections from a power supply into the plug, as shown in the figure below. When plugged into the PLC's power connector socket, the +5VDC connection is to the right, closest to the corner..



Specifications

Hardware Specifications

Power :	
Voltage	4.75 - 5.5VDC
current	300mA maximum < 100mA typical
Digital Inputs :	
Type :	DC voltage input
Input range :	3 to 30 VDC
Input low (or 0) signal :	0 to 0.8V, or open connection
Input high (or 1) signal :	3 to 30VDC
Pulse counter input frequency :	up to 100 KHz (typical) up to 250 KHz (maximum)
Digital Outputs :	
Type :	Sinking transistor
Voltage range :	3 to 30VDC
Current :	500 mA maximum
Motion output pulse frequency	0 to 100 KHz (typical) 0 to 250 KHz (maximum)
Analog Inputs :	
Type :	v5 = 0 to 5VDC: v10 = 0 to 10VDC c = 0 to 20 mA
resolution :	12 bit

Communications :

Upstream :	vLink vLink connector
Downstream :	Two vLink connectors
Maximum Expansion Levels :	3
Maximum number of PLCs in system :	15

Physical Dimensions :

2.5" H x 2.5" W x 0.5" deep

Environmental :

Operating temperature : -40 to 85C

Software Specifications

Application Program Limits (in Branch Expansion*)	
Program Memory :	34K Words
Maximum rungs or function blocks	4K
Maximum # Subroutines	68
Maximum Tagnames	950
Main Program data memory	
Bits	2,048
unsigned 8 bit integers	512
unsigned 16 bit integers	512
signed 16 bit integers	512
signed 32 bit integers	256
floating point numbers	256
Object Memory (used for subroutine data)	
object words	4,096
object bits	up to 65,536
object 8 bit integers	up to 8,192
object signed 16 bit	up to 4,096
object unsigned 16 bit	up to 4,096
object signed 32 bit	up to 2,048
object floating point	up to 2,048
Maximum # objects	292
*(Additional Program resources provided with each Branch Expansion configured for an Embedded Subroutine)	

Terminal Block Connections

Terminal type	Socket connectors and Spring cage capture plug
Terminal spacing :	2.50 mm
Wire AWG	20 to 26 AWG*
* best wire fit is with 22 or 24 AWG	

Ports included :

Exp 11 : Ports C, D, power and 2 vLink
Exp 22 : Ports B, C, D, E, power and 2 vLink
Exp 221 : Ports A, B, C, D, E, power and 2 vLink