

# eAce PLC



## Velocio's Embedded Ace (eAce) PLC

The eAce PLC is a member of the Velocio's groundbreaking series of programmable logic controllers. These PLCs introduce revolutionary new concepts, capabilities, performance and ease of use features to the automation market. They constitute a generational leap over the staid products that have comprised the PLC world for years.

The eAce is the small, stand alone member of the Velocio family, which is designed to plug into a motherboard of your design. This provides you with the capability to add custom circuitry around a standard core. The eAce brings incredible power, in a very small package and at a very low price. Many system applications require 36 points of IO or less, and specialized connections or interfaces which you can design. For those applications, the eAce is the Velocio PLC that fits the requirements.

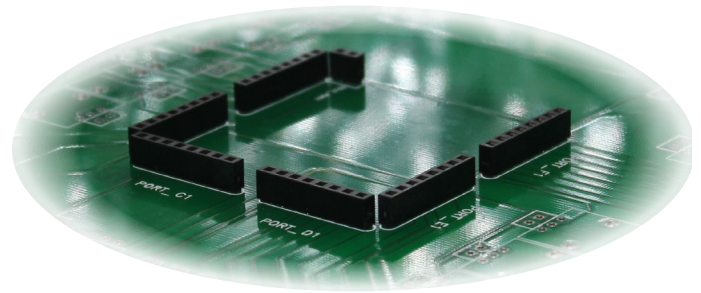

---

*eAce is the version of the Ace PLC to use with Velocio Simulators*

---

eAce PLCs are programmable, using Velocio's vBuilder software. The eAce connects to a PC using a standard USB communications cable. Through this USB cable, the eAce PLC can be programmed, debugged and deployed.

Direct digital inputs to the eAce are any DC voltage signal between 3 and 30 volts. If other levels or signal types are required, your custom motherboard can interface them to the eAce input pins, while taking full advantage of vBuilder to tie custom input signals into the graphical application program.

Direct digital outputs from the eAce are sinking transistor outputs. They can be used do sink to ground (turn on) any DC output up to 30V and 200mA. Again, your custom circuitry can optionally translate eAce digital output signals to types and levels of your choosing.

eAce PLCs can be configured for high speed input counting and stepper motion control. Using vBuilder, you can configure selected digital inputs for either simple high speed pulse counting or for quadrature input pulse counting. Likewise, through vBuilder, you can select digital outputs for pulse and direction stepping motor motion control.

The analog inputs are available in three ranges : 0-5VDC, 0-10VDC and 0-20mA. These three ranges cover the vast majority of analog signal requirements. Resolution is 12 bit (conversion values between 0 and 4095), providing very precise measurement of most common analog signals.

The eAce's small size is another key feature. High end capabilities are packed into a PLC that fits easily on your motherboard. Add custom interfaces and features on your motherboard & you have an advanced system or product, quickly and at low cost.

## Available Versions of the Ace PLC

eAce 11 : 6 digital inputs, 6 digital outputs  
eAce 22 : 12 digital inputs, 12 digital outputs  
eAce 222v5 : 12 dig. ins, 12 dig. outs, 12 analog ins (0-5V)  
eAce 222v10 : 12 dig. ins, 12 dig. outs, 12 analog ins (0-10V)  
eAce 222c : 12 dig. ins, 12 dig. outs, 12 analog ins (0-20mA)

## Applications

- Machine control
- Process control
- Small machine control
- Home automation
- Automated Test
- Motion system control
- Core intelligence for custom designs

## Features

- Up to 36 Inputs and Outputs
  - 12 Digital Inputs
  - 12 Digital Outputs
  - 12 Analog Inputs
- USB connection to PC and other Host devices
- Smallest physical footprint of any PLC
- Plugs directly into motherboard
- Software features at or beyond those of the most advanced PLCs and Programmable Automation Controllers (PACs)
- Program development via vBuilder
  - Graphical program development
  - Flow Chart Programming
  - Ladder Logic Programming
  - Interactive, graphical debug functionality
  - Software reusability
  - Advanced functionality
    - Subroutines, Object orientation, PID, motion, statistics & many more

## Benefits

- Greatly enhanced and efficient development process
- Reduced system cost
- Leverage Velocio's core technology at no design cost
- Reduced hardware development time
- Reduced software development time
- Improved reliability

# vBuilder Software



Like all Velocio PLCs, eAce can be custom programmed for your application's requirements, using Velocio Builder (vBuilder). vBuilder is an application that is distributed free of charge, for use in developing programs for Velocio PLCs.

vBuilder is the most powerful, flexible and easy to use graphical program development software available in the industry. That includes the packages from the industry titans, that will cost you hundreds to thousands of dollars. We're sure that you'll love it.

In vBuilder, you can develop applications using either Flow Chart, or traditional Ladder Logic programming.

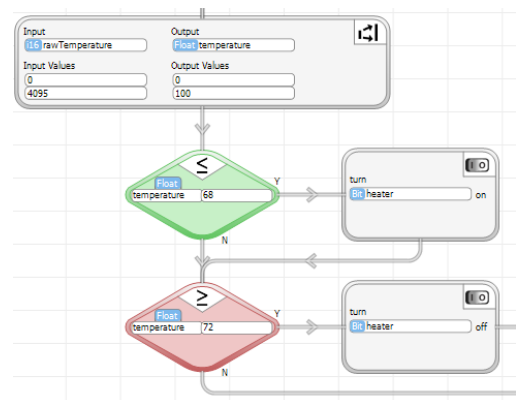

Some vBuilder features include :

- Flow Chart programming
- Ladder Logic programming
- True subroutines
- Object oriented graphical programming
- Distributed program operation
- Single point debug of local or distributed systems

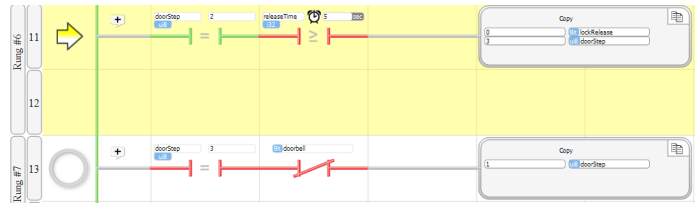

There's so much more. Download vBuilder at [Velocio.net](http://Velocio.net) to see for yourself. You'll notice very quickly that you can develop any program that you can logically define, in a fraction of the time required using other approaches, with easy to use graphical tools - and its fun!

## eAce Inputs and Outputs

Each eAce PLC can connect to 6 or 12 digital inputs, 6 or 12 digital outputs and 0 or 12 analog inputs. There are up to 6 IO ports total. Each IO port is connected to the motherboard through an 8 pin header. Each of these port connectors connect to 6 points of IO.

The layout of eAce IO ports (looking from the top of the eAce), is shown here.

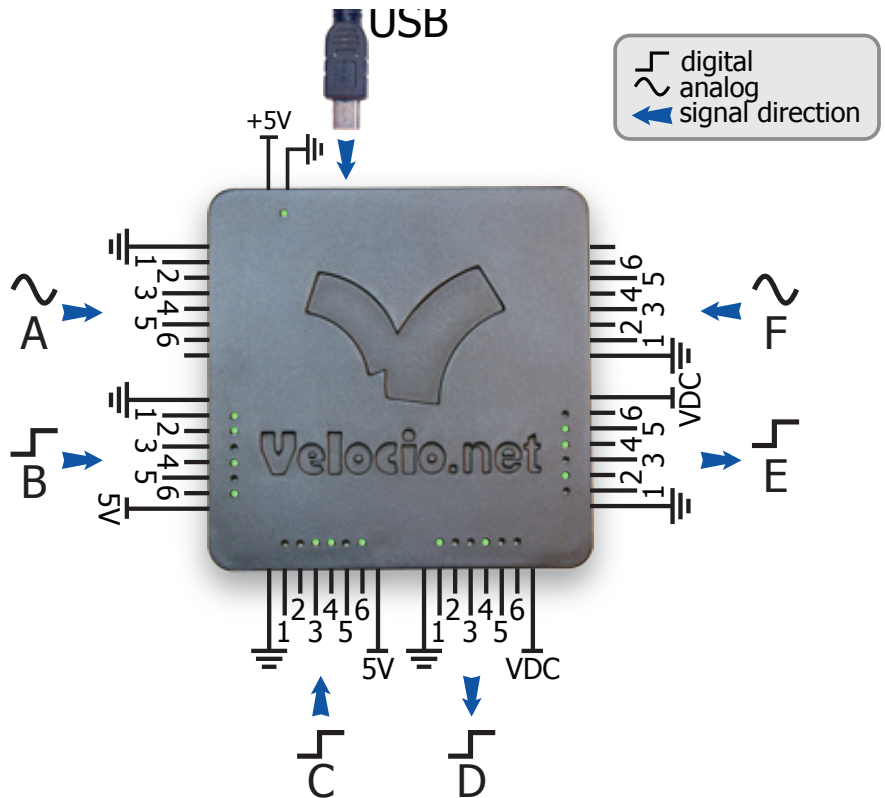

## ◇ Digital Inputs :

eAce PLCs have either 6 (1 port) or 12 (2 ports) digital inputs. Digital inputs sense binary status, such as on/off, switch open/closed, etc. The eAce PLC can interface any DC voltage signal between 3 and 30VDC. Typical system designs utilize 5V, 12V or 24VDC power supplies, which are all within the eAce's signal range.

Any connection to DC voltage between 3 and 30VDC is sensed as a '1'. Any connection to ground (or voltage below 0.8VDC) or an open connection is sensed as '0'. The ground reference of the signal must be connected to the ground terminal pin next to signal 1.

Using vBuilder, one high speed pulse counter can be configured for basic high speed pulse counting (one digital input), or quadrature pulse counting (two digital inputs). The same signal level requirements apply, as listed above.

Interfaces to specialized digital input signals can be designed into the custom motherboard. Simply tie the logic level translation of the signal to the PLC input, in your motherboard design.

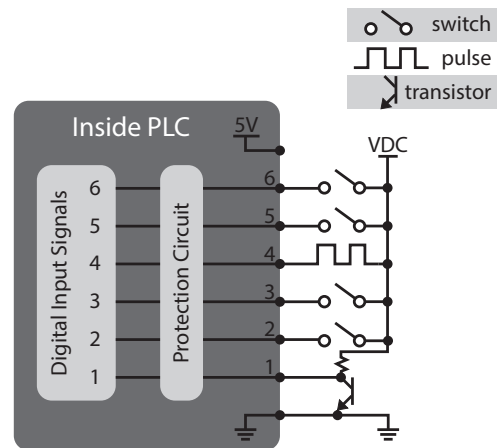

## ◇ Digital Outputs :

eAce PLCs have either 6 (1 port) or 12 (2 ports) digital outputs. eAce digital outputs are sinking transistor outputs. When switched on under program control, they complete the circuit to turn on any connected DC device up to 30VDC and 500mA.

Each output includes diode snubber protection, for inductive load (solenoids, relays, etc.) protection. The supply voltage, up to 30VDC, which is connected to the load devices, must be connected to the VDC terminal pin, next to output 6 of the output port, to enable this protection. All loads connected to a digital output port should be connected to the same DC supply. The load power supply ground must be connected to the ground (next to signal 1) of the output port.

If custom digital output circuitry is required, simply design it into the motherboard. This circuitry can range from simple higher power transistors or relays, to more exotic circuitry which is triggered by the eAce's digital output. Be sure to add a pull up resistor to convert the eAce digital output to a logic signal.

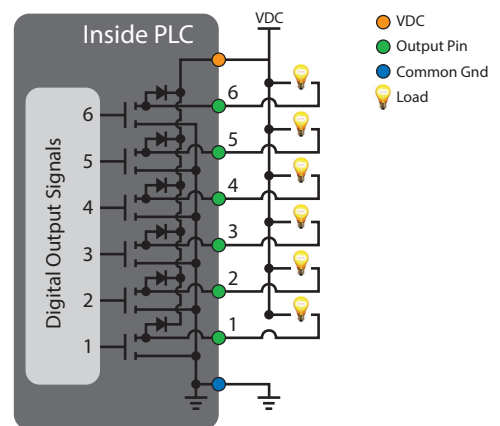

## ◇ Analog Inputs :

eAce PLCs are available with 12 analog inputs (2 ports). eAce PLC analog input interfaces are available for either 0-5VDC, 0-10VDC or 0-20mA.

Analog inputs are normally used to connect to transducer outputs. Such transducers measure some physical parameter, such as pressure, temperature, liquid level, position, pH level, or other such continuously variable measurement. The signal output should be connected to a signal input on the eAce analog port and the transducer return or ground reference line must be connected to the PLC ground, next to signal 1.

eAce PLCs with current input analog input ports (eAce 222c) should be used for analog current signals between 0 and 20 mA. The two most common type of current signals are 4-20 mA and 0-20 mA.

Full range analog signals will convert to a value between 0 and 4095 (12 bits). For 4-20mA inputs, the converted value will be between 820 and 4095. The Scale function in vBuilder can be used to automatically convert the signal value to meaningful data.

As with the digital inputs and outputs, custom conditioning circuitry can be added on the motherboard.

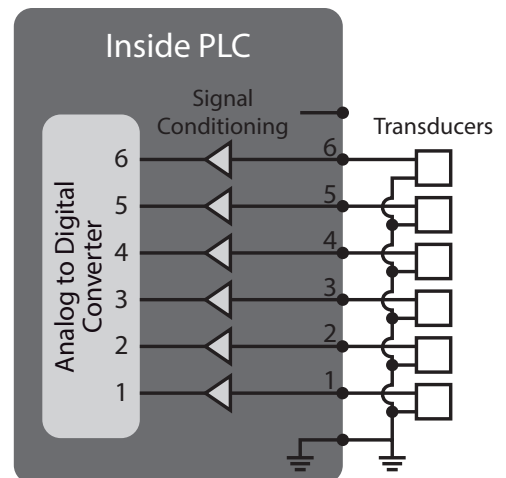

# Mounting Your eAce



Mounting the eAce is a relatively simple proposition. Exactly what that entails depends on whether your eAce is intend for use with a Velocio Simulator or in your custom motherboard.

If you have purchase your eAce as a training and development tool, for use with a Simulator, its simply a matter of plugging it in. Velocio Simulators have sockets, arranged in a pattern that matches the pin pattern of the embedded versions of Velocio PLCs. A typical simulator is shown on the right.

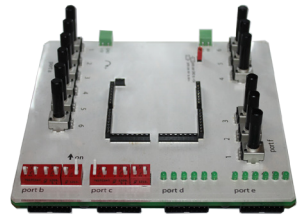

To install in a Simulator, simply line up the PLC pins with the matching sockets, then gently press the PLC into those sockets. All pins should insert very smoothly and easily.



For use with your custom motherboard, the process is basically the same, except that it starts a couple of steps earlier. The eAce comes with sockets for your motherboard. The sockets are standard 0.1" sockets, designed for use with 0.1" spacing, .025" square post headers. The correct number of 8 pin sockets (for IO) and one two pin socket (for PLC power) come included with the eAce. An 8 pin version of those sockets is pictured on the right.

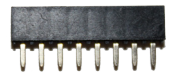

The key is to design your motherboard for the correct pattern of these sockets, just as found on the Simulators. The pattern is illustrated on the right. The actual number of 8 pin sockets involved is dependent on the version of the eAce that you are designing your motherboard for.

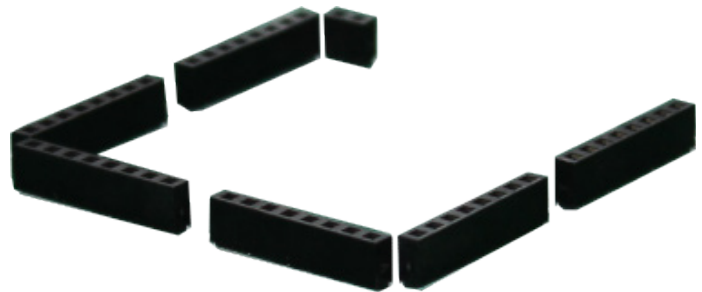

The hole pattern required for mounting an eAce in your design is shown in the lower right corner of this page. Keep in mind that you only need to design in connections for the version of the eAce that you are designing into your system. If the port is not included in the eAce that you are designing for, the matching connector hole pattern is not required. The signals associated for each of the pins is shown on the lower left. The USB does not connect to the motherboard.

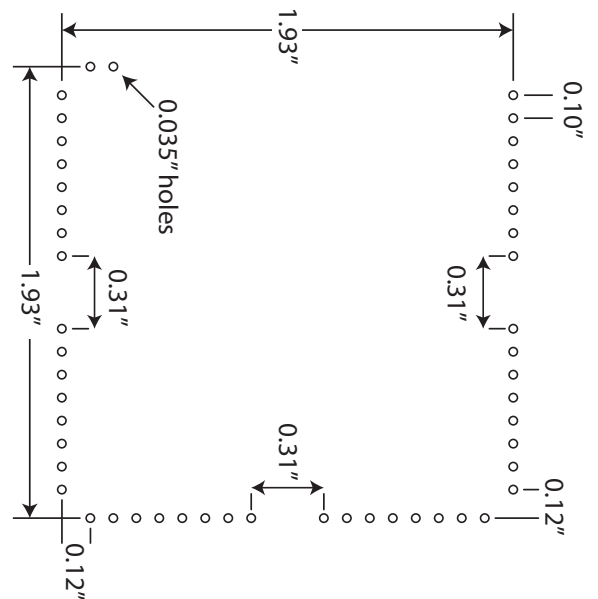
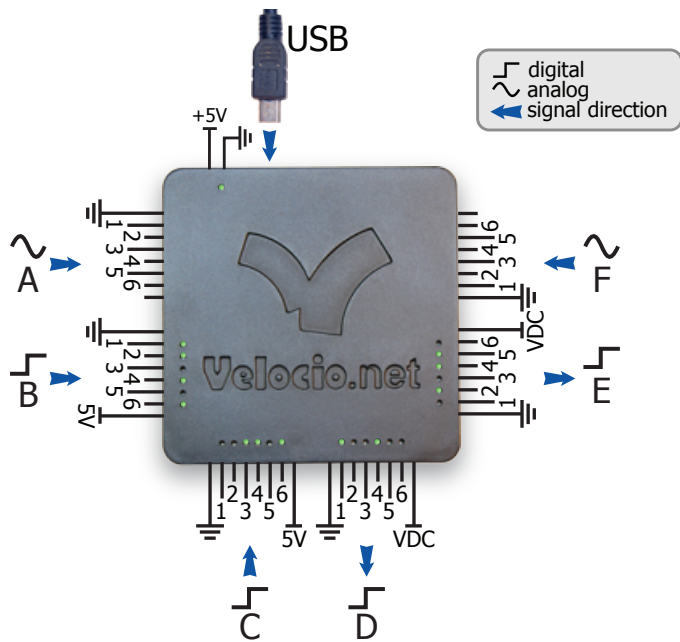

## Specifications :

### Hardware Specifications

Power :	
Voltage	4.75 - 5.5VDC
current	300mA maximum < 100mA typical
Digital Inputs :	
Type :	DC voltage input
Input range :	3 to 30 VDC
Input low (or 0) signal :	0 to 0.8V, or open connection
Input high (or 1) signal :	3 to 30VDC
Pulse counter input frequency :	up to 100 KHz (typical) up to 250 KHz (maximum)
Digital Outputs :	
Type :	Sinking transistor
Voltage range :	3 to 30VDC
Current :	500 mA maximum
Motion output pulse frequency	0 to 100 KHz (typical) 0 to 250 KHz (maximum)
Analog Inputs :	
Type :	v5 = 0 to 5VDC: v10 = 0 to 10VDC c = 0 to 20 mA
resolution :	12 bit

### Communications :

Upstream :	USB Device mini USB connector
------------	----------------------------------

### Physical Dimensions :

2.5" H x 2.5" W x 0.55" deep (to end of pins)
2.5" H x 2.5" W x 0.32" deep (to header pin exposure)

### Environmental :

Operating temperature :	-40 to 85C
-------------------------	------------

### Software Specifications

<u>Application Program Limits (in Ace PLC)</u>	
Program Memory :	34K Words
Maximum rungs or function blocks	4K
Maximum # Subroutines	68
Maximum Tagnames	950
Main Program data memory	
Bits	2,048
unsigned 8 bit integers	512
unsigned 16 bit integers	512
signed 16 bit integers	512
signed 32 bit integers	256
floating point numbers	256
Object Memory (used for subroutine data)	
object words	4,096
object bits	up to 65,536
object 8 bit integers	up to 8,192
object signed 16 bit	up to 4,096
object unsigned 16 bit	up to 4,096
object signed 32 bit	up to 2,048
object floating point	up to 2,048
Maximum # objects	292

### PLC Connections to Motherboard

Connector type :	0.025" square post headers
Connector spacing :	0.1"
Connector configuration :	
eAce 11 :	2 - 1x8, 1 - 1x2 ; ports C, D and power
eAce 22 :	4 - 1x8, 1 - 1x2 ; ports B, C, D, E and power
eAce 222 :	6 - 1x8, 1 - 1x2 : ports A, B, C, D, E, F and power

Pattern shown in layout drawing in this data sheet