

# eBranch Expansion PLC



## Velocio's eBranch Expansion PLC

The eBranch Expansion PLC is a member of the Velocio's groundbreaking series of programmable logic controllers. These PLCs introduce revolutionary new concepts, capabilities, performance and ease of use features to the automation market. They constitute a generational leap over the staid products that have comprised the PLC world for years.

The eBranch Expansion is the embedded version of the Branch Expansion PLC. It is designed to plug into a motherboard - either a Velocio Simulator, or your custom design. By designing the eBranch Expansion into your custom hardware, you can take advantage of all of Expansion's core IO and advanced software features, while adding custom interface circuitry and connections.

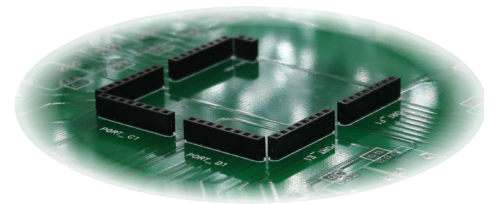

eBranch Expansion PLCs expand the tree for a distributed system. Each Expansion unit contains up to 30 points of IO and can contain its own program. vLink communications ports on the eBranch Expansion communicate autonomously, upstream to the Branch or Expansion unit above it in the tree, and downstream to the next level of Branch Expansion PLCs. Three levels of Branch Expansions are permissible in a system.

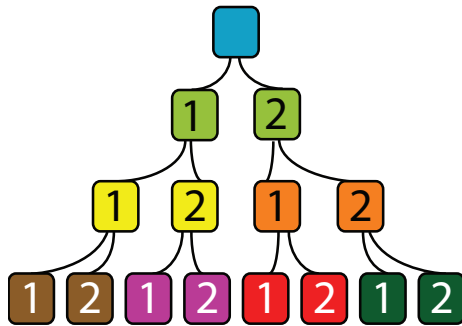

In an application, each Branch Expansion PLC, that is configured as IO, is expansion IO for the next level PLC above it that has a program. If the application places a program in a Branch Expansion, Branch Expansion units that are below it in the tree and configured as IO serve as its expansion IO.

Branch Expansion PLCs are programmable, using Velocio's vBuilder software. They connect to a PC through vLink communications and any Branch and Branch Expansion PLCs above them in the tree. Through a single USB communication link to a PC an entire system of Velocio PLCs can be programmed, debugged and deployed.

Branch Expansion PLCs feature integrated local IO. Up to 12 digital inputs, 12 digital outputs and 6 analog inputs are available. In addition to basic input/output capabilities, the Branch Expansion can be configured for high speed digital pulse counting for either simple pulse or quadrature inputs. It can also be configured for high speed stepper motion pulse and direction control.

High end capabilities are packed into a PLC that fits easily on your motherboard. With your custom circuitry and connections, you have an advanced system or product quickly and at low cost.

### Available Versions of the eBranch Expansion PLC

eExp 11 : 6 digital in, 6 digital out, 2 vLink ports  
eExp 22 : 12 digital in, 12 digital out, 2 vLink ports  
eExp 221v5 : 12 DI, 12 DO, 6 Analog in (0-5V), 2 vLink  
eExp 221v10 : 12 DI, 12 DO, 6 Analog in (0-10V), 2 vLink  
eExp 221c : 12 DI, 12 DO, 6 Analog in (0-20mA), 2 vLink

### Applications

- Machine control
- Process control
- Entire manufacturing line control
- Building automation
- Distributed system control
- Motion system control
- Machine to Machine applications
- Core intelligence for custom designs

### Features

- Up to 30 Inputs and Outputs
  - 12 Digital Inputs
  - 12 Digital Outputs
  - 6 Analog Inputs
- Distributed IO Expansion
- Distributed Processing Platform
- vLink Communications with host
- Two vLink Expansion Communications ports
- vLink communications up to 100 meters (328 feet)
- Smallest physical footprint of any PLC
- Plugs directly into motherboard
- Software features beyond those of the most advanced PLCs and Programmable Automation Controllers (PACs)
  - Program development via vBuilder
    - Graphical program development
    - Flow Chart Programming
    - Ladder Logic Programming
    - Distributed Processing
    - Integrated deployment and debug of distributed processing systems
    - Interactive, graphical full system debug functionality
    - Software reusability

### Benefits

- Automatic communications between system modules
- Greatly enhanced and efficient development process
- Reduced systems cost
- Reduced development time
- Leverage Velocio's core technology at no design cost
- Improved reliability
- Automatic machine to machine operations
- Total system deployment and debug

# vBuilder Software



Like all Velocio PLCs, eBranch Expansion can be custom programmed for your application's requirements, using Velocio Builder (vBuilder). vBuilder is an application that is distributed free of charge, for use in developing programs for Velocio PLCs.

vBuilder is the most powerful, flexible, intuitive, easy to use graphical program development software available in the industry. That includes the packages from the industry titans, that will cost you hundreds to thousands of dollars. We're sure that you'll love it.

In vBuilder, you can develop applications using either Flow Chart, or traditional Ladder Logic programming.

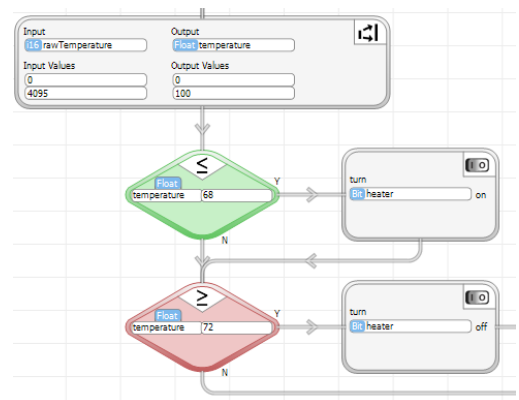

Some vBuilder features include :

- Flow Chart programming
- Ladder Logic programming
- True subroutines
- Object oriented graphical programming
- Distributed program operation
- Single point debug of local or distributed systems

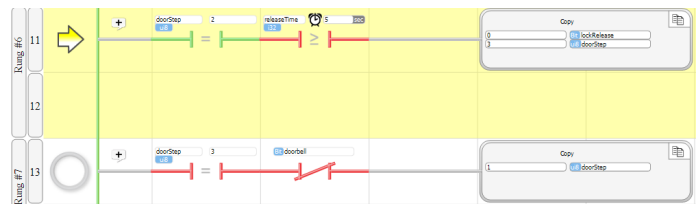

There's so much more. Download vBuilder from [Velocio.net](http://Velocio.net) to see for yourself. You'll notice very quickly that you can develop any program that you can logically define, in a fraction of the time required using other approaches, with easy to use graphical tools - and its fun!

## Distributed IO

In typical control system applications, physical inputs and outputs are located at physically diverse points, commonly in clusters. Traditional PLCs require you to string wire from these distributed locations back to a centralized PLC. This leads to high costs in wiring material and labor. It also potentially results in degraded signal quality, reduced reliability and higher maintenance costs.

Velocio PLCs are designed to allow you to place the IO at the point of application. Each module is linked, via high speed vLink communications. IO modules can be placed anywhere from a few feet apart to 100 meters apart.

The Velocio PLC program treats this distributed IO, just like its local IO. The speed of communication between devices means that sensor status and device activation takes place nearly instantaneously. Wiring time and expense are minimized, while reliability improves and maintenance is reduced.



Embedded Branch Expansions can also be place on a motherboard with other eBanch PLCs for compact, local IO.

## Distributed Processing

Traditional distributed processing is a very difficult undertaking. Sure, the control devices may have communications ports. But the process of configuring the devices, designing the communications, debugging and deploying is something that can take a very capable system engineer many days to weeks.

Velocio PLCs have been designed for distributed processing from the get go. Developing a distributed processing system, with interlinked, independently operating PLCs is no more involved that writing a subroutine for a local PLC. In fact it is directly analogous to writing a subroutine. Define which PLC device each program gets deployed into, define the data that is passed back and forth, then push the program button. The entire system will be programmed. You need not concern yourself with the details of how data is communicated - its done autonomously over vLink.

Debugging the distributed system is also much simpler than with other such systems. With vBuilder, the entire system's operation can be monitored from one PC. All debug operations, including breakpoints and single stepping can be selectively employed on any device in the system in real time.

# Branch Expansion Inputs and Outputs



Each eBranch Expansion PLC can directly connect to 6 or 12 digital inputs, 6 or 12 digital outputs and 0 or 6 analog inputs. There are up to 5 IO ports. Each IO port is connected to the motherboard through an 8 pin header. Each of these port connectors connect to 6 points of IO.

The layout of eBranch Expansion IO ports (looking from the top of the eBranch Expansion), is shown here.

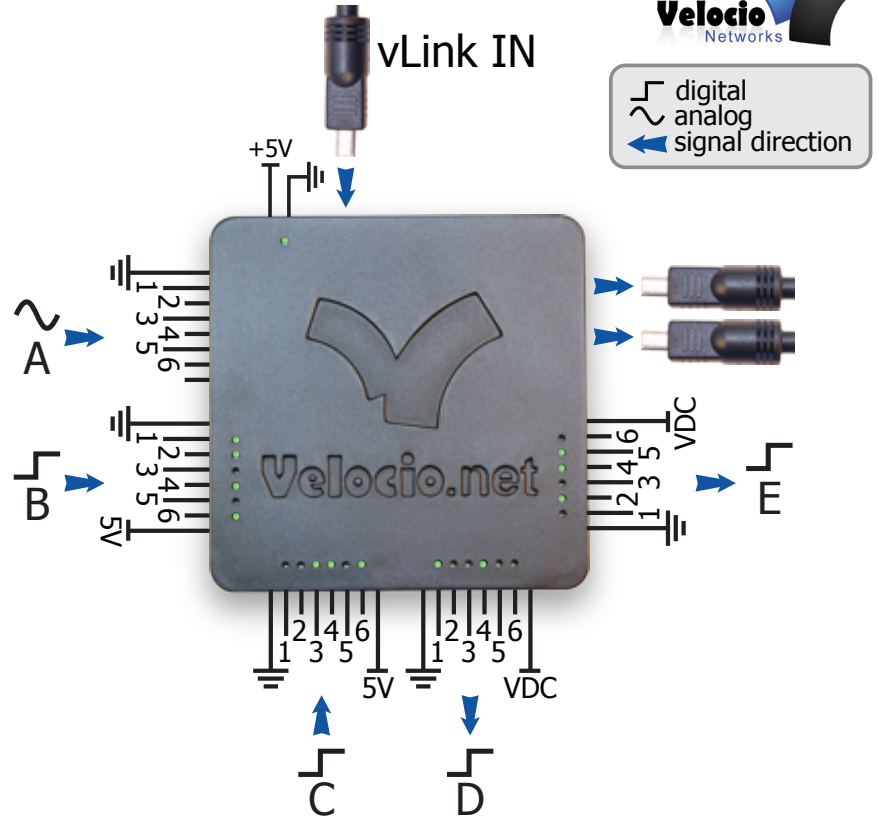

## ◇ Digital Inputs :

Branch Expansions have either 6 (1 port) or 12 (2 ports) digital inputs. Digital inputs sense binary status, such as on/off, switch open/closed, etc. The Expansion can interface any DC voltage signal between 3 and 30VDC.

Typical system designs utilize 5V, 12V or 24VDC power supplies, which are all within the PLC's signal range.

Any connection to DC voltage between 3 and 30 VDC is sensed as a '1'. Any connection to ground (or voltage below 0.8VDC) or an open connection is sensed as '0'. The ground reference of the signal must be connected to the ground terminal pin next to signal 1.

Using vBuilder, one high speed pulse counter can be configured for basic high speed pulse counting (one digital input), or quadrature pulse counting (two digital inputs). The same signal level requirements apply, as listed above.

Interfaces to specialized digital input signals can be designed into the custom motherboard. Simply tie the logic level translation of the signal to the PLC input, in your motherboard design.

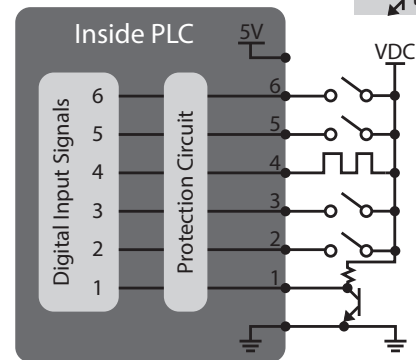
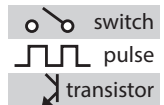

## ◇ Digital Outputs :

eBranch Expansion PLCs have either 6 (1 port) or 12 (2 ports) digital outputs. The digital outputs are sinking transistor outputs. When switched on under program control, they complete the circuit to turn on any connected DC device up to 30VDC and 500mA.

Each output includes diode snubber protection, for inductive load (solenoids, relays, etc.) protection. The supply voltage, up to 30VDC, which is connected to the load devices, must be connected to the VDC terminal pin, next to output 6 of the port, to enable this protection. All loads connected to a digital output port should be connected to the same DC supply. The load power supply ground must be connected to the ground pin (next to signal 1) of the port.

If custom digital output circuitry is required, simply design it into the motherboard. This circuitry can range from simple higher power transistors or relays, to more exotic circuitry which is triggered by the eBranch Expansion's digital output. Be sure to add a pull up resistor to convert the eBranch digital output to a logic signal.

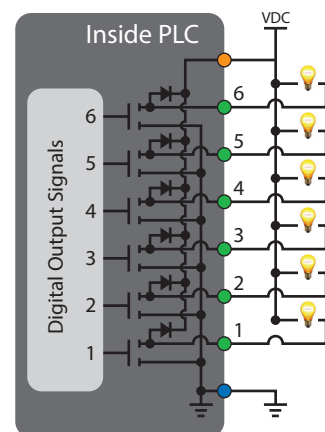
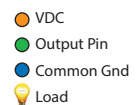



## ◇ Analog Inputs :

eBranch Expansion PLCs are available with 6 analog inputs (1 port). Expansion analog input interfaces are available for either 0-5VDC, 0-10VDC or 0-20mA.

Analog inputs are normally used to connect to transducer outputs. Such transducers measure some physical parameter, such as pressure, temperature, liquid level, position, pH level, or other such continuously variable measurement. The signal output should be connected to a signal input on the Branch Expansion analog port and the transducer return or ground reference line must be connected to the PLC ground pin, next to signal 1.

eBranch Expansion PLCs with current input analog ports (eExp 221c) should be used for analog current signals between 0 and 20 mA. The two most common type of current signals are 4-20 mA and 0-20 mA.

Full range analog signals will convert to a value between 0 and 4095 (12 bits). For 4-20mA inputs, the converted value will be between 820 and 4095. The Scale function in vBuilder can be used to automatically convert the signal value to meaningful data.

As with the digital inputs and outputs, custom signal conditioning circuitry can be added to the motherboard.

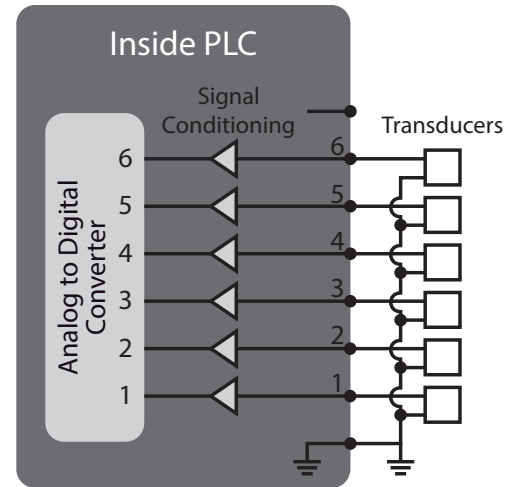

## Connecting Expansion Units

Connecting the eBranch Expansion to a Branch or Branch Expansion unit is a very simple process. If the required connection distance is 6 feet or less, it simply involves plugging a standard vLink cable into one of the two vLink output ports on the higher level PLC and the other end of the cable into the vLink input port of the Expansion unit. vLink cables come in either two or six foot length. Each cable has vLink connector on each end, which look as pictured on the right. The cable connections are identical on both ends. The cable can be connected either way.

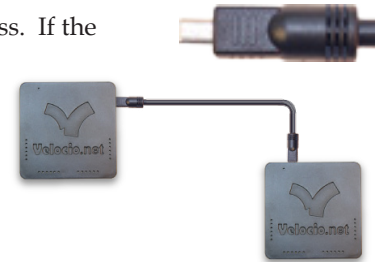

vLink port 1 is located closest to digital output port E. vLink port 2 is furthest from digital output port E.

A vLink connection from a Branch or Branch Expansion to a Branch Expansion is shown on the right.

If the required connection distance is greater than 6 feet, the process is not much more complex. You will need a vLink cable for each end of the connection, a pair of vLink Extenders, and CAT5e cable of the length required to span between two devices. This length can be up to 100 meters (328 feet).

A pair of vLink Extenders is pictured on the right. The Extender labeled vLink Out (black label) connects to the vLink cable that is plugged into the higher level Branch or Branch Expansion. The vLink In (white label) connects to the vLink cable plugged into the Branch Expansion's vLink input port.

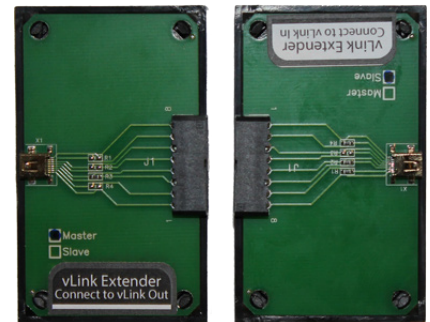

The vLink Extenders each have an 8 position pluggable terminal block that is the same as used for PLC IO. Instructions for inserting the CAT5e cable in the terminal plugs is included with the vLink Extender pairs.

A completed vLink extension is shown in the picture on the right.



# Mounting Your eBranch Expansion



Mounting the eBranch Expansion is a relatively simple proposition. Exactly what that entails depends on whether your eBranch Expansion is intended for use with a Velocio Simulator or in your custom motherboard.

If you have purchased your eBranch Expansion as a training and development tool, for use with a Simulator, it's simply a matter of plugging it in. Velocio Simulators have sockets, arranged in a pattern that matches the pin pattern of the embedded versions of Velocio PLCs. A typical simulator is shown on the right.

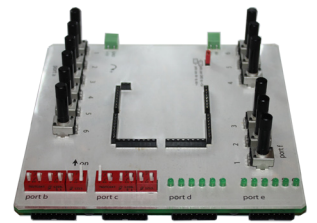

To install in a Simulator, simply line up the PLC pins with the matching sockets, then gently press the PLC into those sockets. All pins should insert very smoothly and easily.



For use with your custom motherboard, the process is basically the same, except that it starts a couple of steps earlier. The eBranch Expansion comes with sockets for your motherboard. The sockets are standard 0.1" sockets, designed for use with 0.1" spacing, .025" square post headers. The correct number of 8 pin sockets (for IO) and one two pin socket (for PLC power) come included with the eBranch Expansion. An 8 pin version of those sockets is pictured on the right.



The key is to design your motherboard for the correct pattern of these sockets, just as found on the Simulators. The pattern is illustrated on the right. The actual number of 8 pin sockets involved is dependent on the version of the eBranch Expansion that you are designing your motherboard for.

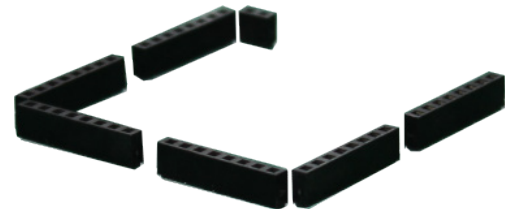

The hole pattern required for mounting an eBranch Expansion in your design is shown in the lower right corner of this page. Keep in mind that you only need to design in connections for the version of the eBranch Expansion that you are designing into your system. If the port is not included in the eBranch Expansion that you are designing for, the matching connector hole pattern is not required. The signals associated for each of the pins is shown on the lower left. The USB and vLink ports do not connect to the motherboard.

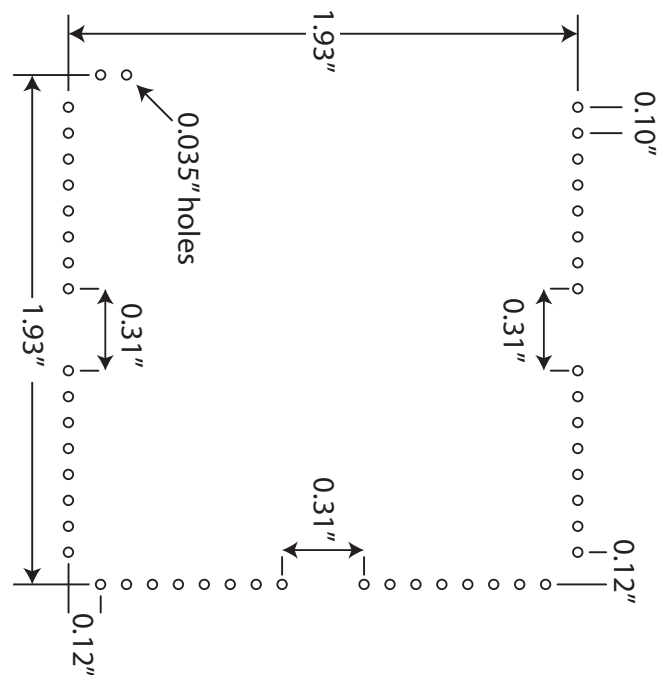
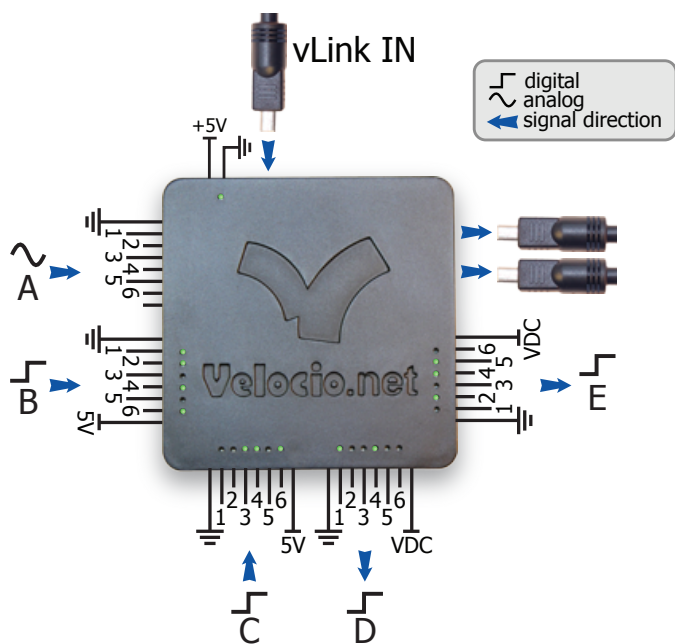

# Specifications

## Hardware Specifications

Power :	
Voltage	4.75 - 5.5VDC
current	300mA maximum < 100mA typical
Digital Inputs :	
Type :	DC voltage input
Input range :	3 to 30 VDC
Input low (or 0) signal :	0 to 0.8V, or open connection
Input high (or 1) signal :	3 to 30VDC
Pulse counter input frequency :	up to 100 KHz (typical) up to 250 KHz (maximum)
Digital Outputs :	
Type :	Sinking transistor
Voltage range :	3 to 30VDC
Current :	500 mA maximum
Motion output pulse frequency :	0 to 100 KHz (typical) 0 to 250 KHz (maximum)
Analog Inputs :	
Type :	v5 = 0 to 5VDC: v10 = 0 to 10VDC c = 0 to 20 mA
resolution :	12 bit

## Communications :

Upstream :	vLink vLink connector
Downstream :	Two vLink connectors
Maximum Expansion Levels :	3
Maximum number of PLCs in system :	15

## Physical Dimensions :

2.5" H x 2.5" W x 0.55" deep	(to end of header pins)
2.5" H x 2.5" W x 0.32" deep	(to header pin exposure)

## Environmental :

Operating temperature :	-40 to 85C
-------------------------	------------

## Software Specifications

Application Program Limits (in Branch Expansion*)	
Program Memory :	34K Words
Maximum rungs or function blocks	4K
Maximum # Subroutines	68
Maximum Tagnames	950
Main Program data memory	
Bits	2,048
unsigned 8 bit integers	512
unsigned 16 bit integers	512
signed 16 bit integers	512
signed 32 bit integers	256
floating point numbers	256
Object Memory (used for subroutine data)	
object words	4,096
object bits	up to 65,536
object 8 bit integers	up to 8,192
object signed 16 bit	up to 4,096
object unsigned 16 bit	up to 4,096
object signed 32 bit	up to 2,048
object floating point	up to 2,048
Maximum # objects	292
*(Additional Program resources provided with each Branch Expansion configured for an Embedded Subroutine)	

## PLC Connection to Motherboard

Connector type	0.025" square post headers
Connector spacing	0.1"

## Ports included :

Exp 11 :	Ports C, D, power and 2 vLink
Exp 22 :	Ports B, C, D, E, power and 2 vLink
Exp 221 :	Ports A, B, C, D, E, power and 2 vLink

Pattern shown in layout in this data sheet