

# eSimulators



## Velocio's eSimulators

Velocio eSimulators are tools for application program development and training. They are simple, effective devices for simulating IO operations for testing and debugging application programs.

For anyone learning PLCs, particularly the next generation PLCs features found in Velocio PLCs, these simulators are the best tools available. They are inexpensive, yet effective.

For any automation application developer, they are keys to success, efficiency and risk avoidance. Through use of Simulators, any system can be developed and very thoroughly tested, on your desktop, before ever connecting to real world devices. Basic logic, various scenarios, exception cases and special conditions can all be systematically simulated and your program logic debugged on the desktop at a pace where actions, parameters and responses are known and observable.

For learning PLC programming and control system fundamentals, Velocio Simulators are the most effective and inexpensive tools available. They are essential for working through the tutorials found in the vBuilder manual. They are also key to working through the training lessons and examples that are on, or will soon be on the Velocio.net web site. Through the process of working through these tutorials and training sessions, any person with a logical mind will be able to learn basic control application programming using Flow Charts and Ladder Logic, as well as the advanced concepts of subroutines, object oriented programming, linked subroutines, embedded objects and distributed processing.

eSimulators are designed for the embedded versions of the Ace, Branch and Branch Expansion PLCs. The embedded PLCs plug directly into the sockets found on the simulators. Individual toggle switches simulate digital input signals. LEDs display individual digital output status. Potentiometers provide analog input adjustment functionality.

Four versions of eSimulators are available. The differences relate to whether the particular unit includes potentiometers for port F (port F analogs are not present on Branch and Branch Expansion units) and whether the IO ports are also brought out to connectors. The optional IO connectors provide the potential for connecting to real world devices.

eSimulators can be used with 0-5V and 0-10V versions of Velocio PLCs. They allow complete simulation of inputs and outputs for the base set of embedded PLCs and partial simulation of units with thermocouple inputs and analog outputs.

### Available Versions of Simulators

eSim 221	12 Dig In, 12 Dig Out, 6 Analog
eSim 222	12 Dig In, 12 Dig Out, 12 Analog
eSim 221p	12 DI, 12 DO, 6 AI, port connectors
eSim 222p	12 DI, 12 DO, 12 AI, port connectors

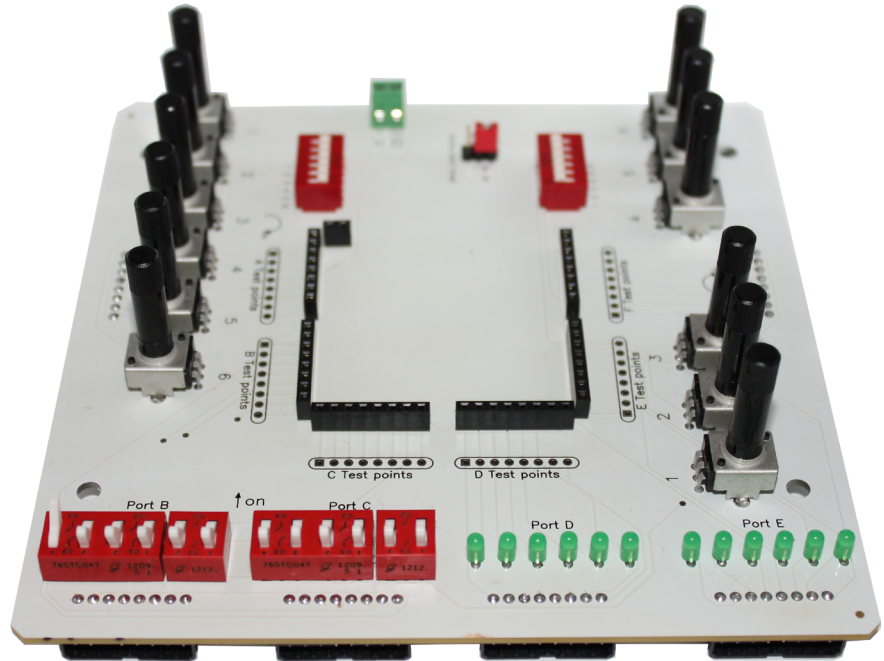

### Applications

- Simulation of application IO
- Training tool
- Development tool
- Debug tool

### Features

- Socket mounting for Velocio embedded PLCs
- Toggle switches for digital input simulation
- LED indicators for digital output status indication
- Potentiometer adjustment for analog input simulation
- 5VDC power connection for PLC power
- Jumper selection for analog source
- Optional port connectors

### Benefits

- Desktop simulation
- Simple debug tool
- Direct manual control of IO conditions

### Compatibility List

	eSim			
	221	222	221p	222p
eAce 11, 22	X	X	X	X
eAce 222v5, 222v10	P	X	P	X
eBranch 11, 22	X	X	X	X
eBranch 221v5, 221v10	X	X	X	X
eExp 11, 22	X	X	X	X
eExp 221v5, 221v10	X	X	X	X
others	P	P	P	P

X = full simulation  
P = Partial simulation

# eSimulator Features and Options



The illustration on the right show an eSimulator, with all of the options (eSim 222p). The port connectors, which are present on the bottom of the simulator, are shown rotated to edge view for easier viewing.

From this illustration, you can see the fundamental feature elements available. As shown, any Velocio embedded PLC will plug into the sockets on the top side of the Simulator. Component spacing allows for unimpeded USB and vLink cable insertion. This allows the full analog versions (eSim 222 and 222p) to be used with any eAce, eBranch or eBranch Expansion. Analog output and thermocouple input features, for ePLCs that have them, are not simulated.

At the top of the picture is the power connection for 5VDC power to run the PLC. Below the power connection and between the two banks of DIP switches, is a jumper. This jumper allows you to select either 0-5V or 0-10V as the range for analog signals coming from the potentiometer analog simulations. The 10V supply is generated by the simulator, from the 5V input.

As shown, the IO port connectors which are present on the eSim 221p and 222p, are identical to the socket connectors on the non-embedded Velocio PLCs.

The two, six position DIP switches, shown above the embedded PLC, allow you to select whether the analog signal for each individual analog input comes from the potentiometer (adjustable knob) or from a connection to the analog port connectors (A and F ports). These DIP switches are only present on the eSim 221p and 222p models.

The picture on the right shows a detail highlight of the various Simulator features and options.

- Knobs simulate Analog Inputs (port F is present on eSim 222 and 222p only)
- Switches simulate Digital Inputs
- LEDs display Digital Output state
- Jumper sets either 0-5V or 0-10V analog input simulation
- Analog Input Port Connector (221p and 222p only)
- Digital Input Port Connector (221p and 222p only), can determine on an input by input basis whether to use switch of external input.
- Digital Output Port Connector (221p and 222p only)
- DIP switches for point by point selection of analog source from either the Knob or port connection (221p and 222p only)

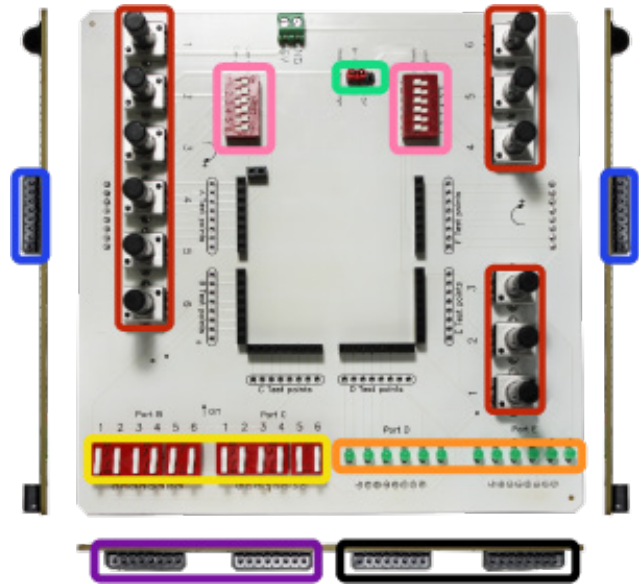
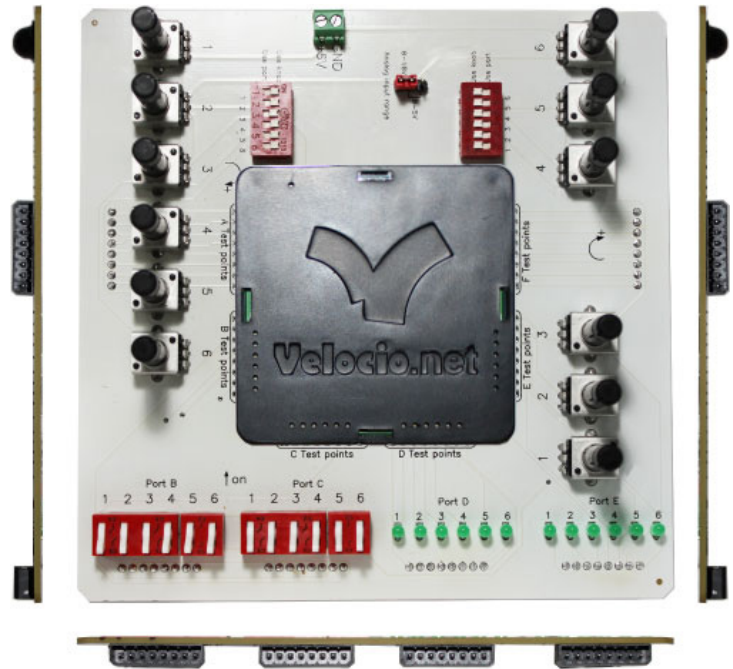

## Digital Inputs

Digital inputs are simulated on the eSimulators through two banks of six toggle switches - one for each port. If no external connection is made through a port connector, digital input simulation is simple and basic. Any toggle switch that is flipped toward the PLC is 'on', resulting in the input tag bit in the PLC program reading a 1. Any switch that is flipped away from the PLC is 'off', resulting in the input tag bit reading a 0.

The circuit for each digital input signal is shown on the right. With no connection to the port connector, the toggle switch switches between ground and 5VDC. There is a 33,000 ohm resistor between the switch and the actual input pin. Since the digital input senses voltage, the input at the input pin will be whatever voltage the toggle switch is toggled toward.

eSim 221p and 222p provide the capability to connect an actual digital input to any particular input signal. The digital input signals come in through the port connectors on the under side of the simulator. The connector wiring and positions are documented in the data sheets of the non embedded versions of the PLC.

In order to cause the digital input to reflect the status of the external digital input, the toggle switch must be placed in the proper position. That proper position is dependent on the digital input circuit which provides the input signal. On the right are the three signal cases that are possible. Any other circuitry employed will fundamentally fit one of these three cases.

The top figure shows a simple switch input that connects the input pin to some positive voltage, when on. It opens up, when off. For this type of input signal, flip the toggle switch to the off position. The 33Kohm resistor will isolate the toggle switch from the external input when the external switch is closed. When the external switch is open, the PLC digital input will be a low, or 0.

The second figure is very similar to the first. In this case the external input switches between closed to VDC and closed to ground. In this case, it's actually not real important which direction the toggle switch is placed in. The external signal will override the toggle switch. We recommend that you place the toggle switch in the off position.

The third figure shows a circuit that has a pull up through a resistor to VDC and a switch that closes to ground. This is the case with many electronic circuits. In this case, flip the toggle switch to the on condition, so the toggle switch acts as simply another very weak pull up on the signal and will not affect the external signal.

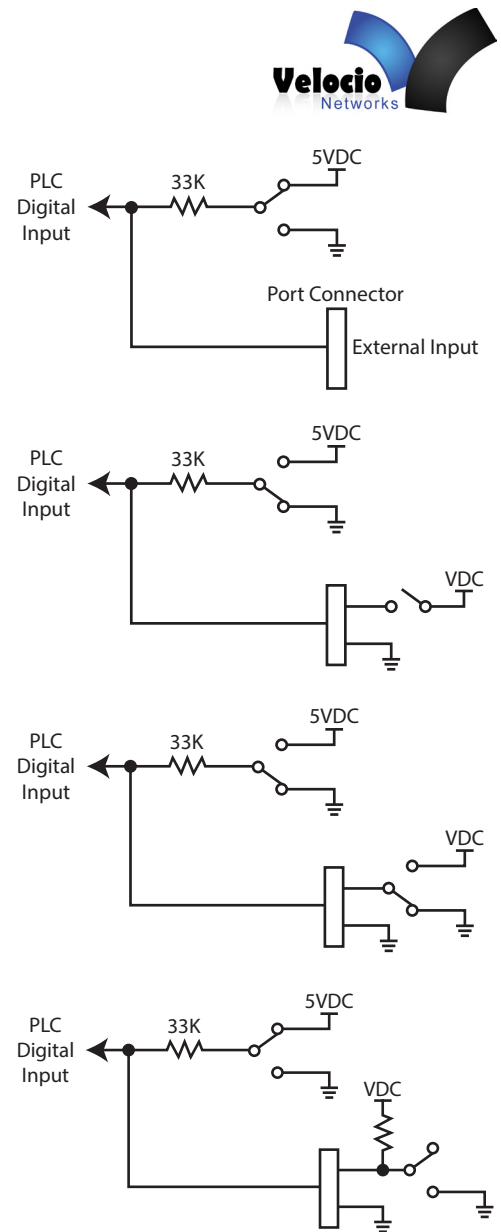

## Digital Outputs

Digital Outputs are very straight forward. The PLC digital outputs are "open drain" or "open collector" transistor outputs. When they are turned on, they act as a closed connection to ground. When they are off, they open that connection. The LED indicators on the eSimulator modules connect the LED, through a resistor to each of the outputs. When the PLC output is on, the associated LED on the eSimulator will light.

If external outputs are connected to the output port of an eSim 221p or eSim 222p, the same connection to ground will be made. The requirements for connecting to external digital outputs are the same as for connecting to the PLC digital outputs. The load supply voltage ground must be connected to the ground connection, next to signal 1. The load supply VDC must be connected to the VDC pin, next to signal 6. The signal output will sink the load to ground when on. The circuit is illustrated in the figure on the right.

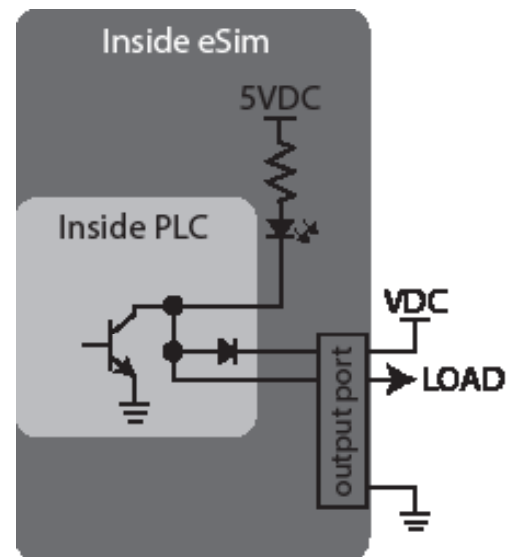

## Analog Inputs



Analog Inputs are simulated on the eSimulator with potentiometers. There is one potentiometer for each analog input. The eSim 221 and 221p simulators have potentiometers for port A only. The eSim 222 and 222p simulators have potentiometers for both the A and F analog ports.

The figure on the right illustrates the signal input to the each analog input. The eSimulator can be jumpered to connect either the 5VDC power input that powers the PLC, or the generated 10VDC supply to the potentiometer. Each PLC input is always connected to the external analog input port for the eSim 221p and 222p. To connect the input to the associated adjustment knob, place the DIP switch setting in the “use knob” position. If you are using the knob adjustments, you should not have external inputs plugged into the associated port.

To use external analog signals, place the associate DIP switch position(s) in the “Use port” position. The external analog inputs should be connected to the eSimulator analog input ports in the same manner as the non-embedded PLCs. Signal ground must be connected to the ground connection, next to signal 1.

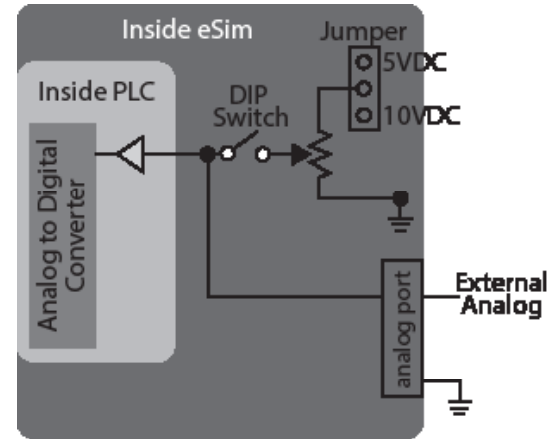

## Specifications :

### Power Connection

Primary Power :	
Voltage	4.75 - 5.5VDC
current	300 mA maximum < 100 mA typical

### Potentiometers

Resistance	5K ohm
------------	--------

### Physical Dimensions :

5.5"L x 5.5"W

### Terminal Block Connections :

Power terminal type	Terminal block
pin spacing	3.5mm
wire AWG	16 to 26 AWG
IO port connectors*	pluggable terminal block
type	
pin spacing	2.5mm
wire AWG	20 to 26 AWG

\* for eSim 221p and 222p

### Ports included :

eSim 221	A, B, C, D & E
eSim 221p	A, B, C, D & E + port connectors
eSim 222	A, B, C, D, E & F
eSim 222p	A, B, C, D, E & F + port connectors